



OGK KABUTO CO., LTD.

6-3-4, NAGATANISHI, HIGASHIOSAKA, OSAKA, 577-0016, JAPAN.
TEL:+81-6-6748-7806 FAX:+81-6-6747-8023

 Kabuto Global Web Site
www.ogkkabuto.com

No.E-F17-2024-APR/QD1

SAFETY MEETS STYLE



F17 SERIES



Instruction Manual



For full descriptions of this product and other languages.

https://www.ogkkabuto.co.jp/motorcycle/etc/e2206_manu.html

BEFORE USE

PRIOR TO USE, READ THIS INSTRUCTION MANUAL THOROUGHLY AND KEEP THIS FOR FUTURE REFERENCE

Instruction Manual • Table of Contents

Table of Contents P-1

Part Descriptions P-2

NOTES BEFORE USE..... P-3

–Exterior–

1 **Ventilation** P-5

2 **Wake Stabilizer** PAT. / **Crest Spoiler** PAT.P. P-7

3 **Shield** P-8

Pinlock® Original Insert Lens P-12

–Interior–

4 **Chinstrap** P-15

5 **Cheek Pads** P-17

6 **Inner Pad** P-20

7 **Wind Shutter** P-22

8 **Breath Guard** P-23

Inquiries, Repairs and RequestsP-24

Part Descriptions

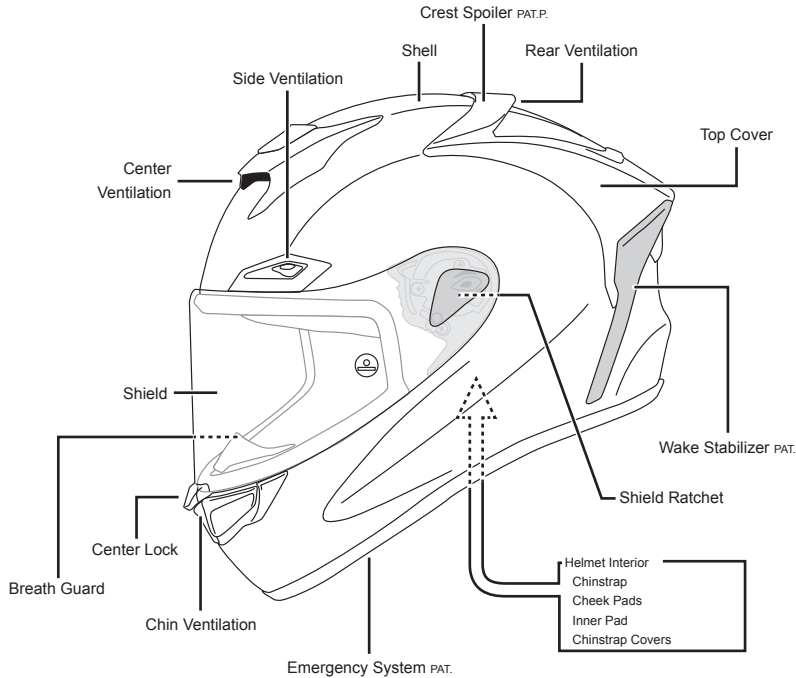

Accessories



NOTES BEFORE USE

Thank you very much for purchasing the Kabuto helmet.

This Instruction Manual describes proper handling, various functions, and removal and replacement of each part of this helmet. Please read this Instruction Manual thoroughly prior to use.

After reading this, keep the Manual for future reference.

The helmet is just an element of protection, intended to minimize the risk in the event of an accident. It cannot ensure complete safety. Use this helmet properly with understanding this point very well.

Please understand and follow the instructions and information in this Instruction Manual to enjoy your pleasant and safe motorcycle ride.

! Select the proper size!

It is very dangerous to wear too large size of the helmet. This may wobble while riding on a motorcycle. If you wear too small size helmet, it tightens up and hurts your head. Thus, it is important to select the helmet size that fits you.

! Fasten the chinstraps before riding

The helmet is designed to be retained by straps under the chin. In order to assure proper protection, the helmet should fit your head. When worn, adjust it to rest properly on the head, securely fasten the chinstraps to ensure safety. The chinstraps prevent the helmet from coming off in most cases.

! Never use the helmet once impacted

Liners are essential for the intended performance of the helmet. This helmet has been designed to absorb the impact energy when components such as shell and liners are partially destroyed by an impact. Even if visually no damage is apparent, it could be seriously damaged by a small impact. Regardless of the degree of damage, the helmet that underwent an impact or was abused even only once should not be used anymore. Always handle the helmet with care and make sure that no one sits on it or drops it.

! Never remodel the helmet

In order to fully maintain the performance of this helmet, do not attempt to take it apart or change it in any manner such as making holes in it, or cutting it (or any of its parts).

! Helmet care and cleaning

To clean the helmet, use common ph-neutral detergent diluted with clear water. The cloth should not be soaking wet, then wipe it gently with dry cloth. Finally wipe away the detergent solution by using a cloth rinsed in clear water, and leave the helmet to completely dry, but not in direct sunlight. With regard to helmets with removable interiors, carefully read the instruction manual for that model before attempting to remove the interiors and carry out cleaning according to the explanation provided.

To clean the helmet do not use saline water or hot water (above 50°C).

! Do not paint or apply solvent

Any paint, glue, adhesive stickers, etc. (or the use of detergents and solvents other than those prescribed) may not only reduce the original protective performance of the helmet considerably, but may also cause damage to the helmet that cannot be detected by the naked eye.

! Handle your helmet with care

Do not toss your helmet over a floor or sit on it. The helmet absorbs an impact every time it is handled roughly and its impact-absorbing capacity will be decreased. Handle your helmet with care so as to assure its full intended function in the event of an accident.

Do not use your helmet for any purpose other than to use for protecting your head while riding.

! The storage of the helmet

After using the helmet, stow it away in the helmet bag and store on a level place such as a shelf; the helmet may be damaged if it rolls around or falls down. Do not leave the helmet in direct heat above 50°C e.g. next to a heater or under direct sunlight in a car.

! Shield care and cleaning

After using your helmet, with a wet soft cloth, lightly wipe off any grime (e.g. dead insects, dirt, sand, dust, etc.) on the shield and then fully wipe it clean using a dry soft cloth. When the shield gets wet (e.g. rainwater), it should always be wiped with a soft cloth after use.

When cleaning the shield, never use any petroleum-based solvents or detergents containing abrasives.

Contact with petroleum products and other solvents may impair the optical properties and reduce the mechanical strength.

To clean the shield, apply some common ph-neutral detergent diluted with clear water using a soft cloth and wipe gently. Finally, wipe it dry with a lint-free soft cloth. To clean the shield, do not use saline water or hot water (above 50°C).

! Cautions for shield

If the shield is marked "Day Time Use Only", visibility is limited to daylight conditions and it is not suitable for use at night.

Tinted lenses are not suitable for use at night.

A shield and goggles with scratches lowers the visibility and this is very dangerous. Such shields should never be used at night and should be replaced.

Contact with petroleum products and other solvents may impair the optical properties and weaken the strength of the shield. Never try to open and close or to remove the shield while riding.

! Notes for use of full-face helmet

When you wear a full-face helmet, the temperature in the helmet is maintained nearly constant during riding but the surroundings are constantly changing since you are moving at a high speed. For this reason, in case of sudden rain, immediately after entering a tunnel or in a place with a large difference in height such as a mountain path cause difference in temperature between inside and outside of the helmet. As a result, the shield of the helmet may be fogged suddenly. In case such a risk is expected, please use caution with adjusting the shield or slowing down your speed in advance. Never open and close the shield or adjust the ventilation shutter while riding since it is very dangerous. Thus, operate them before riding.

–Exterior–

1 Ventilations

Ventilation System

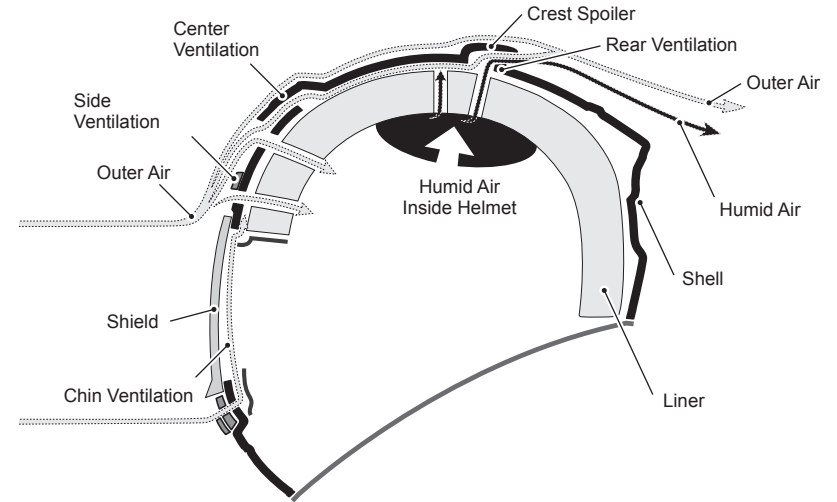

– Side Ventilation –

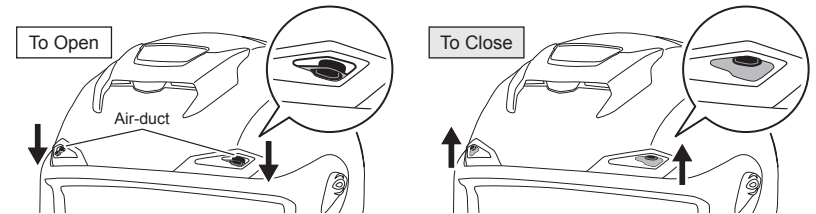

– Center Ventilation –

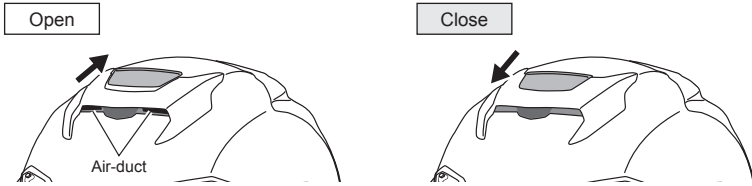

– Chin Ventilation –

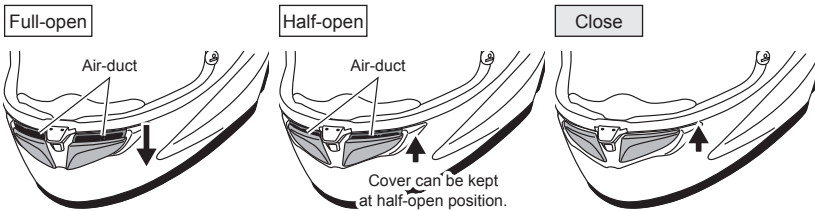

! CAUTION!

Ventilation will be damaged, if subjected to strong forces.

! WARNING!

- Never operate them while riding. It is very dangerous.
- Never customize your helmet. Airducts are designed in the optimal sizes and quantities for the safety.

2 Wake Stabilizer PAT. / Crest Spoiler PAT.P.



Wake Stabilizer PAT.

Kabuto's unique system, controls the airflow around the helmet and reduces loads while riding.

! CAUTION!

Do not lift the helmet with wake stabilizer, or give it a strong impact. As it maybe damaged.

Crest Spoiler PAT.P.



Crest Spoiler PAT.P.

This device suppresses the force that lifts the helmet.

! CAUTION!

Do not apply a strong impact on the crest spoiler or it will be damaged.

3 Shield

– Removal –

- 1, Fully open the shield (Fig. 1)
- 2, Pull the shield in the sense of the arrow while pressing down the release button to remove. (Fig. 2)

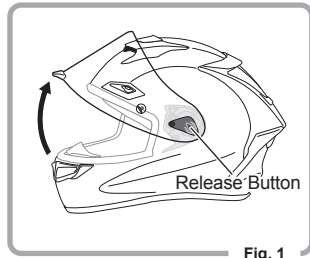

Fig. 1

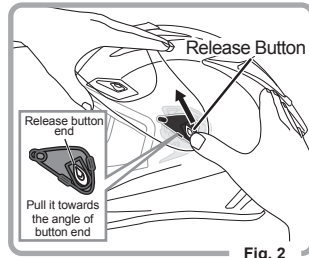
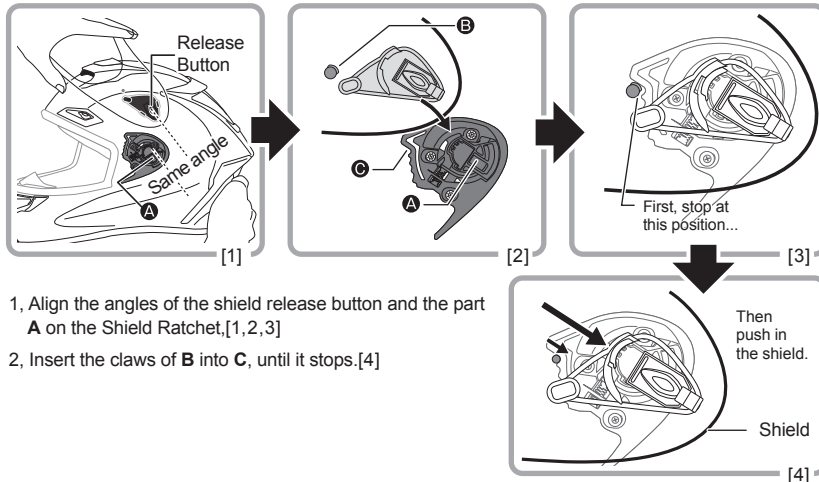

Fig. 2

! CAUTION!

- Do not pull or twist the shield by force to remove it. Such action may damage the shield and ratchet system.

– Attaching –



- 1, Align the angles of the shield release button and the part A on the Shield Ratchet.[1,2,3]
- 2, Insert the claws of B into C, until it stops.[4]

! CAUTION!

- Do not push or twist the shield by force when installing it. Such action may damage the shield and ratchet system.

! WARNING!

- Make sure that the shield is securely installed and that it properly opens and closes before riding the motorcycle. improper or insecure attachment may cause a failure in opening and closing operation of the shield or lead to the removal of the shield while riding, thereby causing a great risk. If the opening and closing operations are not properly performed or abnormal noise is heard during these operations, recheck and repeat the installation procedure from the start.
- Shield is a consumable item. Do not continue to use if the scratches or dirt are significant. Replace such a shield soon.

< GC-01 >

GC-01 can maintain the lubricity and adhesiveness of the shield by applying it. Periodically apply it to the position shown in the figure and wipe it off with a cloth.

Using the supplied cloth or a soft cloth, apply a small amount of GC-01 to the window rubber.

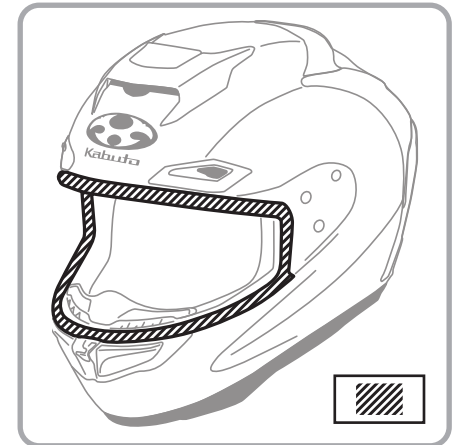

! CAUTION!

- Do not use for any other purpose.
- Shake the bottle well before use.
- Do not use on anti-fog shields.

< Shield Ratchets >

Shield Ratchet appears when the shield is completely removed.

– Removal –

Turn the Shield Ratchet Screws on the Shield Ratchet counterclockwise using a proper size Phillips screwdriver to unscrew.

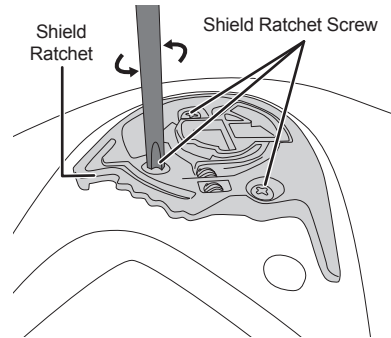

! CAUTION!

- Use the proper tools otherwise the screws and parts may be damaged.
- Do not lose the removed screws.

– Installation –

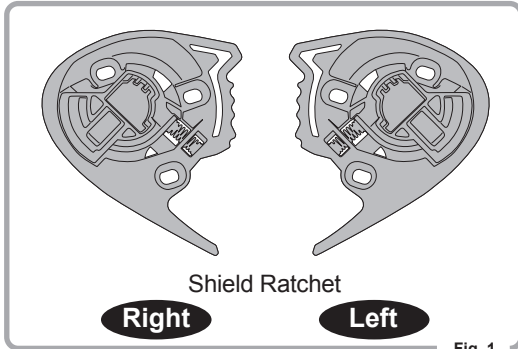

1, Check the side of the Shield Ratchet (Fig.1)

Fig. 1

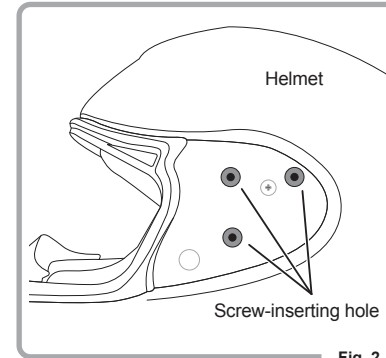

Fig. 2

2, Align the shield ratchet holes with the holes on the helmet. (Fig. 2)

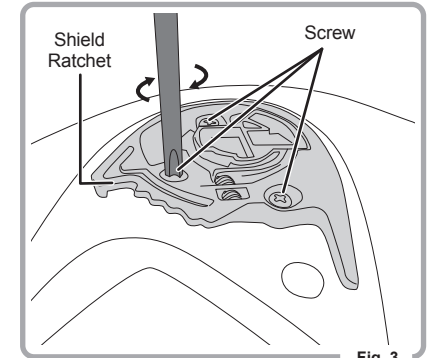

Fig. 3

3, Fasten each Shield Ratchet Screw clockwise securely. (Fig. 3)

! CAUTION!

- Do not tighten more than necessary. It can damage screws and other parts.

! WARNING!

- Install the Shield Ratchet securely and check to see that the shield can be closed to the lowest position and opened and closed correctly.
- Check and fasten the Screws regularly. Riding with the loosened Shield Ratchet Screws is very dangerous as the shield may be removed while riding.

< Shield Post >

Read "Pinlock® Original Insert Lens" for attaching Pinlock® Original Insert Lens.

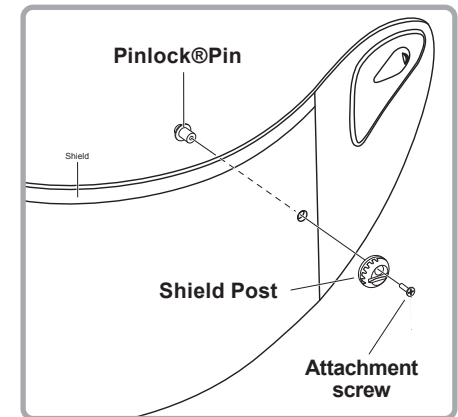

Pinlock® Original Insert Lens

PINLOCK®

Pinlock® Original Insert Lens has international patent protection and is a registered brand name of Pinlock systems B.V. Further patents have been applied for.

Pinlock® Original Insert Lens:

Pinlock® Original Insert Lens prevents the shield from fogging caused by thermal changes in winter or rainy weather etc.

Maintaining the proper space between the shield and the Pinlock® Original Insert Lens provides clear vision by balancing the inner and outer temperature.

– Attachment –

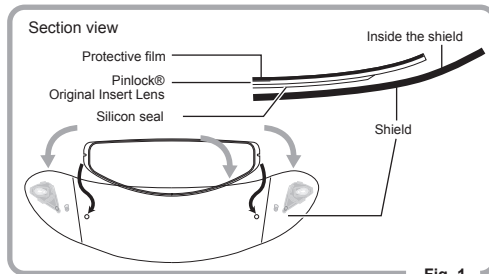

Fig. 1

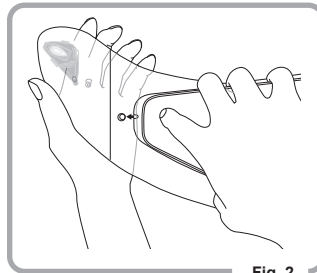

Fig. 2

1. Apply the silicon seal side of the Pinlock® Original Insert Lens on inside the shield, without peeling off the protective film on the lens. At the time, apply the Pinlock® Original Insert Lens on inside the shield by clicking it into the eccentric pins. (Fig 1 and 2)

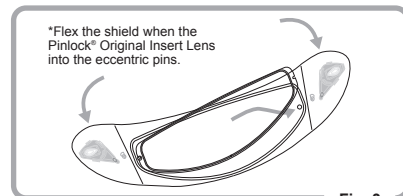

Fig. 3

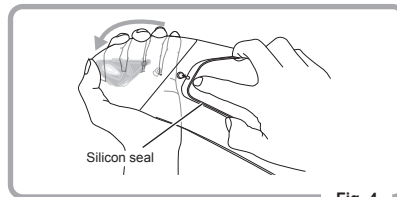

Fig. 4

2. Flex the shield carefully until the shield becomes flat. Then, click the other side of the Pinlock® Original Insert Lens into the eccentric pins and then allow the shield to return carefully to its original curved shape. Make sure the Pinlock® Original Insert Lens to be fit inside the chase (Fig. 3,4 and 5). (Follow 3 on next page)

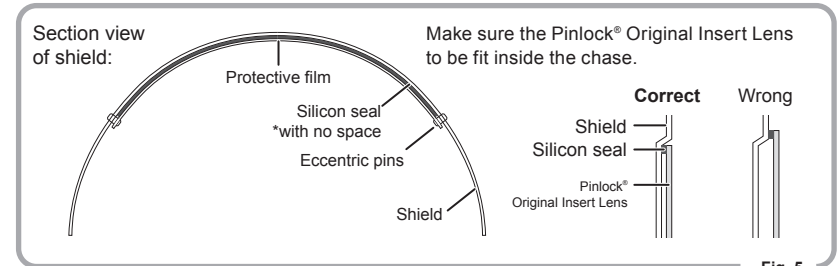

Fig. 5

3. Make sure if the overall silicon seal of the Pinlock® Original Insert Lens is attached firmly to the shield by mounting the shield on the helmet. If there is any space between them, refer to “How to Adjust Pinlock® Original Insert Lens after Attachment” and adjust the lens.

*Please mount the shield on the helmet when checking if the Pinlock® Original Insert Lens is attached firmly to the shield. Otherwise, the shield might be spread out by the pressure from the lens and it cannot be assured if the lens has attached on the shield firmly.

4. Peel off the protective film on the Pinlock® Original Insert Lens.

– Removal –

1. Remove the shield from the helmet.
2. Remove the Pinlock® Original Insert Lens from the eccentric pins with flexing the shield. (Fig.6)

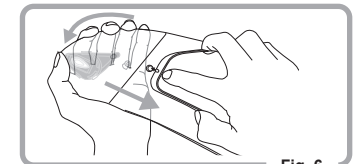

Fig. 6

– Attachment –

Adjust the Pinlock® Original Insert Lens if there is any space between the lens and the shield.

1. Remove the shield from the helmet and detach the Pinlock® Original Insert lens from the shield.
2. Adjust the eccentric pins by turning them with a tool. (Fig. 7)
3. Fit the Pinlock® Original Insert Lens back on the shield. Make sure the Pinlock® Original Insert Lens and the shield do not have any space in-between after attaching the shield on the helmet. If there is any space please follow the same steps again.

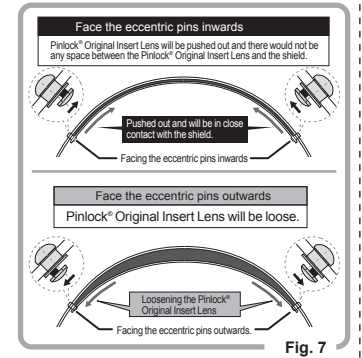

Fig. 7

* Please read next page carefully.

! CAUTION!

- Flex the shield properly when fitting the Pinlock® Original Insert Lens. Otherwise, eccentric pins may be damaged.
- Clean the inside of the shield before applying the Pinlock® Original Insert Lens. Pay attention not to touch the anti-fogging part of the silicon seal on the Pinlock® Original Insert Lens.
- Do not use any petroleum products, thinner, glass cleaner, etc. It will degrade the material of the Pinlock® Original Insert Lens.
- Do not leave the Pinlock® Original Insert Lens where the temperature may surpass 50°C or near a heater, neither use a drier nor fire for drying. Heat may degrade the material of the Pinlock® Original Insert Lens.

! CAUTION *Pinlock® Original Insert Lens

- Pinlock® Original Insert Lens is for exclusive visors.
- If rain or water drops come in the space between the Pinlock® Original Insert Lens and the shield, please detach the Pinlock® Original Insert Lens from the shield and dry them out. Then, reattach the Pinlock® Original Insert Lens on the shield.
- Please remove the Pinlock® Original Insert Lens at times for maintenance. Otherwise the silicon seal of the lens would adhere to the shield.
- Do not use any shields or pins other than exclusive ones for the Pinlock® Original Insert Lens.
- Please be informed that if you are riding with the ventilations closed or using the Wind Shutter, may cause the Pinlock® Original Insert Lens to become fogged.
- Please replace Pinlock® Original Insert Lens if the anti-fog performance decreases and/or being scratched.
- Silicon seal may come into view depending on the riding position.

-Interior-

4 Chinstrap

When the chinstrap covers are removable and washable.

- Detaching -

Undo the snap at the end of each chinstrap and pull the chinstrap cover.

- Attaching -

let the chinstrap go through from the upper portion of the chinstrap cover and fasten the snap.

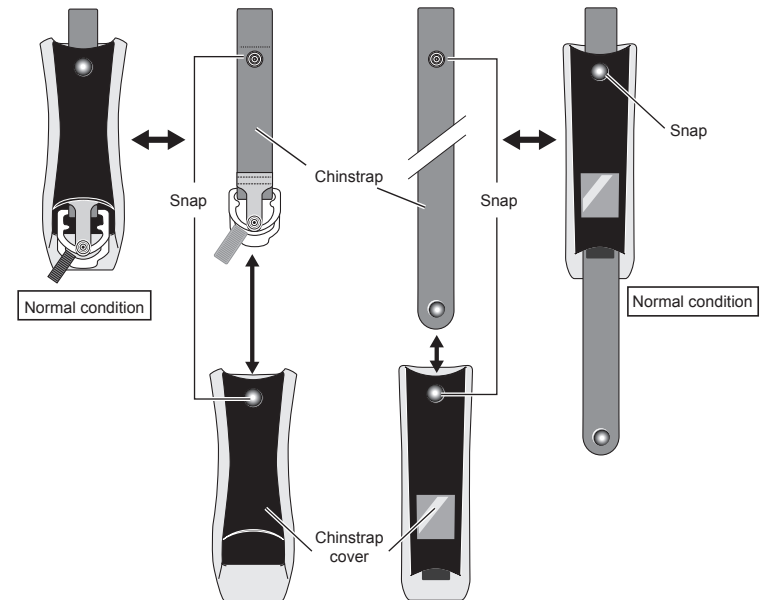

! CAUTION!

- When washing put them into a washing net to prevent fibres from being damaged.
- Do not attach the chinstrap cover in the reverse direction, otherwise the D-ring will be hidden.

< Fastening Chinstraps >

Let the strap go through the D-rings, and pull the strap to the direction of the arrow and fasten the snaps.

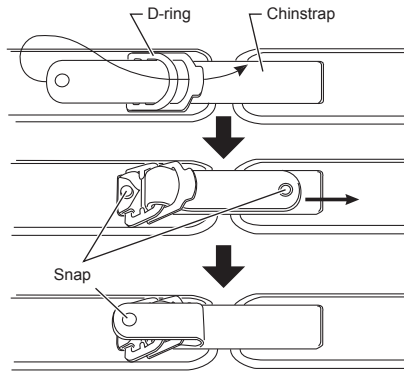

! WARNING!

Be sure to fasten the chinstrap securely. Otherwise, in case of falling down or an accident while riding, the helmet may drop off, and may cause serious injuries.

5 Cheek Pads

– Remove –

Hold the cheek pad firmly, remove the two snaps and hook and loop fastener on the back side of the cheek pad, and pull it out from the front side to remove it.(Fig.1)

! CAUTION!

When removing the cheek pad, be sure to remove it from the base where the snap is attached. Pulling forcibly may cause damage to the cheek pad or snap.

NOTE Ear Caps

Ear cap is attached with hook-and-loop fasteners on the shell under the cheek pads, and available to detach if desired.

*Ear cap is common to both left and right.

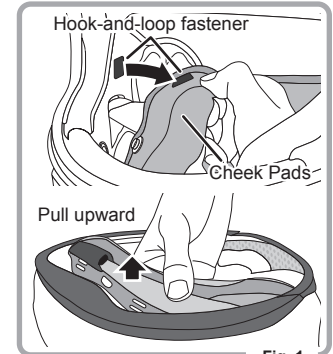
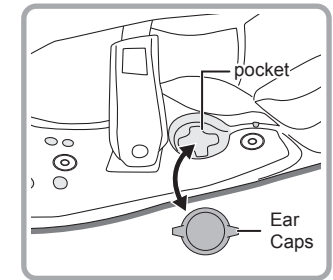

Fig. 1



- Attachment -

1, Check the direction of the cheek pad.

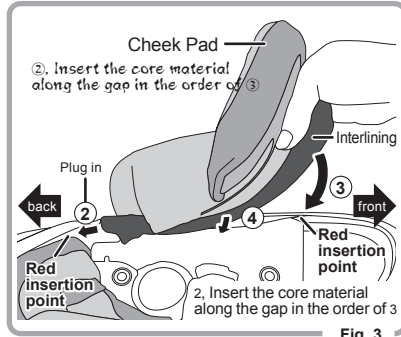
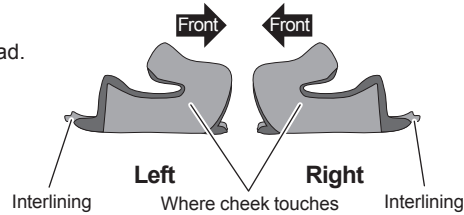

Fig. 3

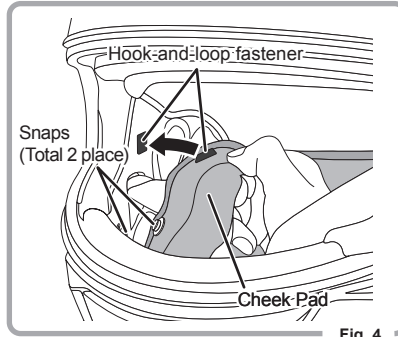

Fig. 4

- 2, Insert the tip of the Interlining behind the cheek pad into the red insertion part. (Turn up the Rubber trim a little to find the red insert.) (Fig. 3)
- 3, Insert the front end of the Interlining into the red insertion part on the front side.
- 4, Insert the Interlining along the gap.
- 5, Fasten the two snaps and Hook-and-loop fastener. (Fig. 4)

! CAUTION!

Do not ride a motorcycle without the cheek pads or with them attached improperly.

< Kabuto Emergency System PAT. >

By pulling out the sponge inside the cheek pad, in the event of an accident the rescuer can smoothly remove the helmet.

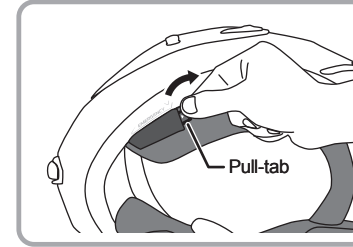

- 1, Pull out the pull tab on the zipper and open the zipper.

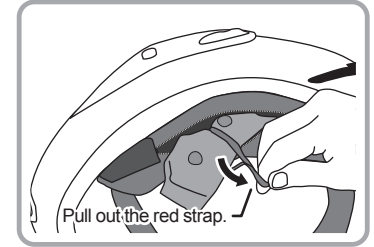

- 2, Pull out the red strap and pull out the sponge in the cheek pads.

! CAUTION!

- Do not use this system except in emergencies.

6 Inner Pad

– Remove –

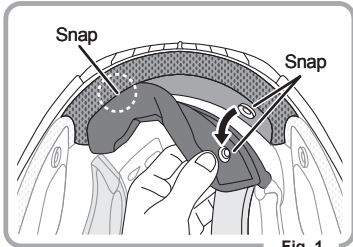

Fig. 1

1, Undo the snaps at the rear.(Fig. 1)

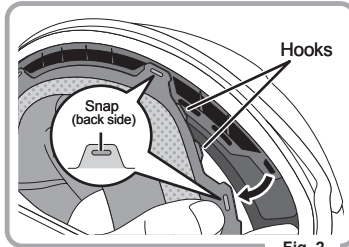

Fig. 2

2, Undo the 4 snaps and the hooks at the front, then the inner pad can be removed. (Fig.2)

– Attach –

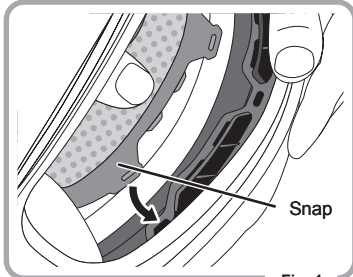

Fig. 1

1, Attach the snap at the temple areas as shown in Fig.1.

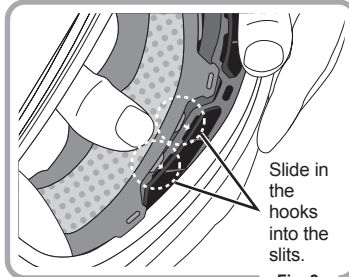

Fig. 2

2, Slide in the in order. Repeat the 1,2 procedure on every hooks and snaps.

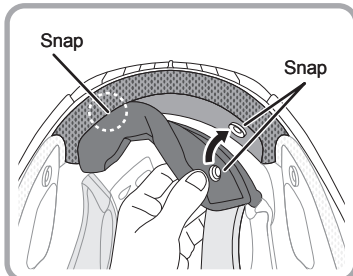

Fig. 3

3, Fasten the 2 snaps at the rear to complete attaching the pad.

! CAUTION!

- Gently remove the pad. Do not pull the interlining and snaps by force. otherwise the parts may be damaged.
- Before riding, be sure to attach the inner pad completely. It is very dangerous to use the helmet with the inner pad attached improperly.

< KF17 JOINT BASE >

– Install –

Insert the hook and loop fastener into the slit on the helmet in the order of A→B→C.

– Remove –

Pull the tab at the bottom toward you.

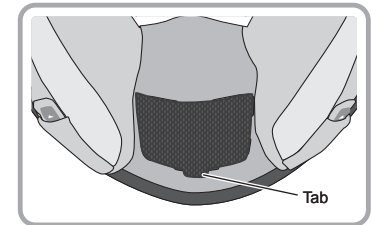
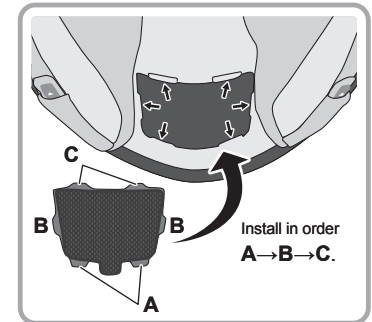

! CAUTION!

- When removing the joint base, gently pull the tab at the bottom. Pulling it forcibly may damage the joint base or the slit on the helmet.

7 Wind Shutter

The Wind Shutter is included as the standard accessory. This accessory is intended to reduce the introduction of wind from chin area while riding.

– Install –

1, Referring the (Fig.1) to distinguish the outside and inside.

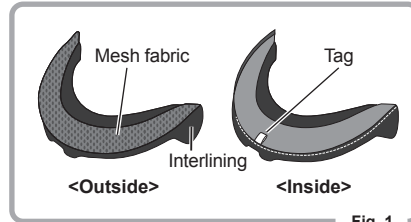

Fig. 1

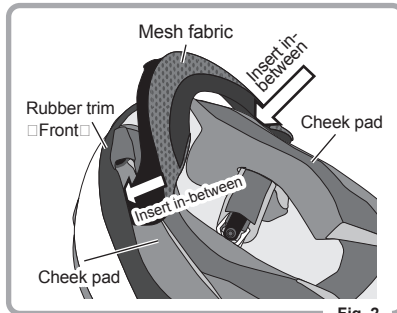

Fig. 2

Tuck the interlining with fingers into the inside of the rubber trim from both sides towards the center.

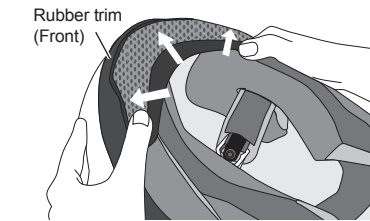

Fig. 3

2, Insert the interlining of both sides of the Wind Shutter in-between the front area of the cheek pad and the rubber trim. (Fig.2)

3, Attach it uniformly from both sides toward the center. (Fig.3)

Tuck in the interlining to such an extent that the edge of the frame rubber is almost flat with the Wind Shutter.

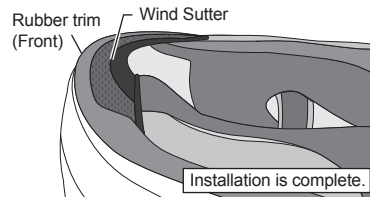

Fig. 4

4, Tuck in the interlining to such an extent that the edge of the frame rubber is almost flat with the Wind Shutter to complete the attachment (Fig.4).



◀ Installation video.

! CAUTION!

- Install the Wind Shutter securely. Incomplete installation may cause the drop of the Wind Shutter while riding.
- Do not use an adhesive agent or the like but install the Wind Shutter with the procedure given above. Some components of an adhesive agent may damage the material of the helmet.

– Remove –

Firmly hold the interlining area around the center of the Wind Shutter and pull it up.

! CAUTION!

To remove the Wind Shutter, gently pull up and take off carefully. Otherwise the cloth and/or part may be damaged.

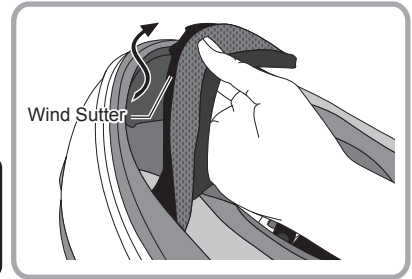

8 Breath Guard

– Remove –

Grip the Breath Guard securely, and pull it out to remove it.

– Attach –

As shown in the figure, insert the three attachment parts into the ports on the helmet.

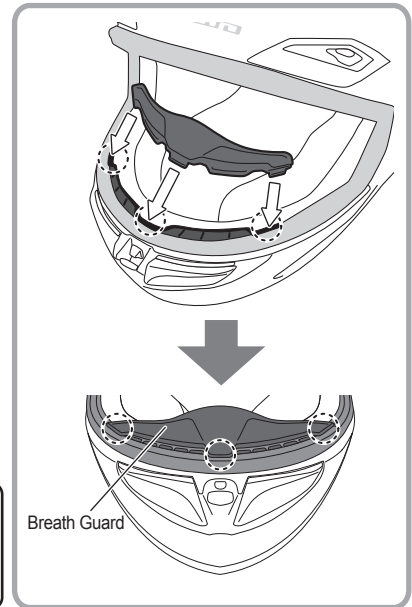

! CAUTION!

Do not use any adhesive agents. Some components of adhesive agents may damage the helmet.



COOLMAX® is used for the interior fabrics so as to allow quick evaporation of sweat and brings cool and comfortable use.

– Evaporate sweat quickly to achieve cool and comfortable use –

- When sweat comes out from the body, COOLMAX® allows discharging moisture to the outside and takes in air from the outside to cool and dry your body. As a result, the temperature on the body surface is lowered and exercise great moist adjustment accordingly.
- COOLMAX® provides a natural touch to the texture with soft and light weight and good permeability properties.

*COOLMAX® is the registered trade name of INVISTA.

Contact for inquiries on the products and request for repair:

Contact the address given below for inquiries on the products and request for repair

Request for repair

- Contact a sales store or the authorized Kabuto dealers for request of repair.
- Before sending back the helmet to us, contact the dealers for detailed information and report on repair in advance. Without prior information and report, there may be a case that quick action for repair cannot be taken.
- ***After we receive an article to be repaired, there may be a case that we cannot accept your order for repairing if it is judged that the safety performance of the helmet cannot be assured by repairing.***

Parts that cannot be repaired

- The following parts cannot be repaired in terms of assuring the performance of the helmet.
- **Helmet body (Shell)**
- **Shock absorbing liner**
- **Chinstraps including D-rings**
- Contact authorized Kabuto dealers for detailed information on repair and others.